

Name:

Period:

Seat#:

**Required Sections:** (Refer to R-15 for guidelines and requirements. Make note of any specific changes given by your teacher in class.)

**Prelab:** Purpose, Materials, Reagent Table, Procedures, and set up Data Tables before you get to class.

**During Lab:** Data section – Fill out your data table that is already set up from the prelab.

**Post-lab:** Calculation section, Post-Lab Questions, Post-Lab Two Pager done on separate Worksheet.

## Background

In this experiment, you will conduct, observe, and measure the process of electroplating. This process is used to deposit a layer of metal, such as chromium, copper, or gold, onto another metal. As a commercial process, electroplated coatings are used to improve appearance, resist corrosion, or improve hardness of metallic surfaces. This experiment describes one method of producing a copper coating on a brass key or other suitable metallic object.

You will prepare an electrochemical cell by using a copper strip and a brass key as the electrodes. The electrodes are immersed in a solution containing acidified copper (II) sulfate. As you apply a potential to the electrodes, you will be transferring Cu atoms to the surface of the key.

This process is expressed in equation form as

$$\text{Mass deposited at an electrode} = \frac{I \times t \times (MM)}{96,500 \times n}$$

$I$  is the current in amperes;  $t$  is the time that the current is applied, in seconds;  
 $MM$  is the molar mass of the element that is deposited;  
 $n$  is the number of moles of electrons/mol; and 96,500 is  $F$ , the Faraday constant.

## Objectives

In this experiment, you will

- Prepare and operate an electrochemical cell to plate copper onto a brass surface.
- Measure the amount of copper that was deposited in the electroplating process.
- Calculate the amount of energy used to complete the electroplating process.

## Materials

Chemicals	Equipment		
* Electrolyte solution – 1.0 M CuSO <sub>4</sub> in 1.0 M H <sub>2</sub> SO <sub>4</sub>	• Computer with USB port, or a USB adaptor	• Connecting wires with alligator clips (to use with Current Probe) x4	• Bare copper wire, 18 gauge
• Vinegar (acetic acid, 5%)	• LabQuest Mini	• 250mL beaker	• 1cm x 10cm copper strip (or more of the bare copper wire)
• Solid sodium chloride, NaCl	• Logger Pro	• 150mL beaker	• Brass key
• Distilled H <sub>2</sub> O	• Vernier Constant Current System OR Current Probe and 1.5 volt DC power supply	• Balance	
		• Steel wool	

## Procedure

### Both Constant Current System and Generic Power Supply Users

- 1) Obtain and wear goggles.
- 2) Use steel wool to clean a brass key and a strip of copper, which are the electrodes of the electrochemical cell.
- 3) In a 150mL beaker, obtain a small amount of the salt and vinegar solution your teacher made (3 g of NaCl with 15 mL of vinegar). Wash the key and the copper strip in this salt/vinegar solution. Rinse the key and copper strip with distilled water and dry each metal piece.
- 4) Use an analytical balance to determine the mass of the key and the mass of the copper strip. Record these two masses in your data table.

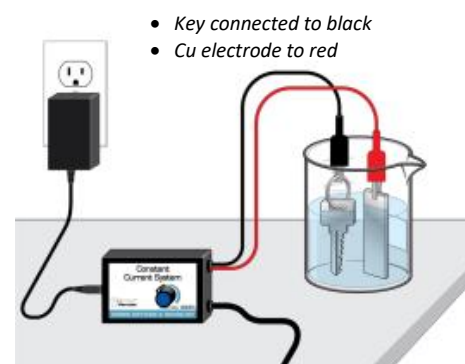

Figure 1

## Dougherty Valley HS Chemistry - AP Electrochemistry – Electroplating

---

- 5) Fill a 250 mL beaker about 3/4 full with the electrolyte solution.
- 6) Attach a 7 cm length of bare copper wire to the brass key to act as a handle, so that it is easier to completely immerse the key in the electrolyte solution.

### Constant Current System Users Only (Others proceed to the Generic Power Supply Section)

- 7) Gently turn the dial of the Constant Current System counterclockwise to confirm that it is in the minimum current position. Clip the wire handle on the key and the copper strip to the proper leads (See Figure 1). Important: You will not place the electrodes in the cell until Step 10.
- 8) Plug the Constant Current System into a powered electrical outlet. Connect the sensor cable to Channel 1 of the Vernier computer interface. Connect the interface to your computer with the proper cable.
- 9) Start the Logger Pro program on your computer. The default mode of data collection is suitable for this experiment.

### Generic Power Supply Users

- 7) Obtain a DC power supply and a Vernier Current Probe. Use connecting wires, with alligator clips, to connect the DC power supply, Current Probe, and the electrodes (See Figure 2). Important: You will not place the electrodes in the cell until Step 10.

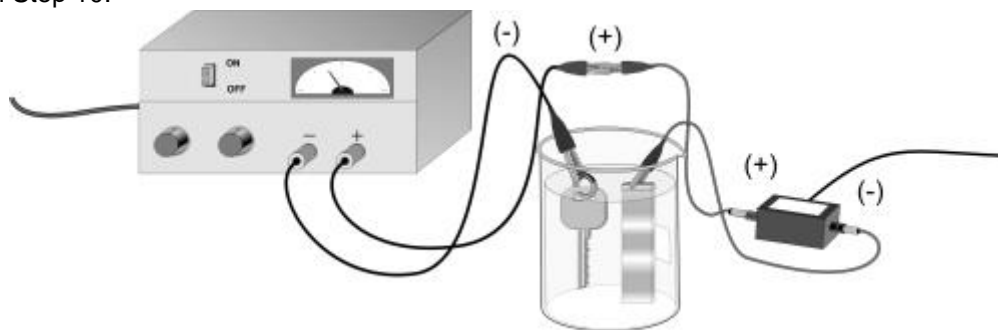

Figure 2

- 8) Connect the Current Probe to Channel 1 of the Vernier computer interface. Connect the interface to your computer with the proper cable.
- 9) Start Logger Pro on your computer. Open file "21 Electroplating" from the *Advanced Chemistry w Vernier* folder.

### Both Constant Current System and Generic Power Supply Users

- 10) Place the key and the copper strip into the electrolyte solution in the beaker. Make sure that the key is completely immersed in the solution, and keep the two electrodes as far apart as possible.
- 11) Click Collect to begin the data collection. Allow 5–6 data points to be collected to establish a baseline. Adjust the current to the 0.2–0.3 A range. Observe the electrolysis. Note the slow deposition of copper on the surface of the key. Data collection will run for 30 minutes.
- 12) After data collection has run for ~28 minutes, turn off power supply. Allow data collection to run to completion. After data collection stops, carefully remove the copper strip and the key from the electrolyte solution. Rinse the two metals with distilled water. Gently dry the copper strip and key so as not to remove copper.
- 13) Measure and record the mass of the dry copper strip and key.
- 14) Do NOT Discard the electrolyte solution, your teacher will instruct you what to do with it and how to take care of the electrochemical cell.

## Dougherty Valley HS Chemistry - AP Electrochemistry – Electroplating

---

### Data Table

1. Make your own data table! Remember, you need to make sure your data table has all required elements!

Initial mass of copper electrode (g)	
Final Mass of copper electrode (g)	
Initial mass of key (g)	
Final mass of key (g)	
Average current (A)	
Time of current application(s)	

2. Glue in a copy of your Logger Pro graph below your data table.

### Calculations

- Record any, and all, manipulation of numbers in your calculation section.
1. Calculate the number of coulombs of charge that passed through the electrolytic cell.  
(Hint: Make sure you are using the proper unit of time for your calculation.)
  2. Use your current vs. time data to calculate the theoretical number of moles of copper that should have plated out onto the brass key.
  3. Use your data from measuring the mass of the electrode and the key to calculate the actual number of moles of copper that plated out.
  4. Calculate the percent yield of copper

### Post Lab Discussion Questions

1. Was this lab an example of a Galvanic or Electrolytic cell? Explain.
2. Was the electroplating process spontaneous or nonspontaneous?
3. What are the algebraic signs for the Cell Potential and for Gibbs Free Energy, based on your answer to questions 1 and 2?
4. What was the purpose of plugging the set up into a power source?
5. Draw your cell and label with any/all relevant information that would be relevant to your cell. Things like anode, cathode, direction of electron flow, etc etc etc...
6. What metal was being plated onto the key? Where was the metal being plated onto the key coming from?
7. Write the oxidation and reduction half-reactions for this process. Label which one is taking place at the anode, and which at the cathode.